

Przemysław CZERNIEJEWSKI, Jarosław FILIPIAK¹

Fish biology

**BIOLOGICAL AND MORPHOLOGICAL CHARACTERISTICS
OF VENDACE, *COREGONUS ALBULA* L. FROM LAKES
DRAWSKO AND PEŁCZ**

**CHARAKTERYSTYKA BIOLOGICZNO-MORFOLOGICZNA SIELAWY
(*COREGONUS ALBULA* L.) Z JEZIOR DRAWSKO I PEŁCZ**

**Department of Fisheries Management of Inland Waters, Agricultural University of Szczecin,
Poland**

Comparative biological and morphometric studies were carried out on vendace from lakes Drawsko and Pełcz in two seasons of the year. The summer sample covered 106 specimens of this fish from Drawsko Lake and 120 specimens from Pełcz Lake, while the autumn sample consisted of 110 and 104 specimens, respectively. This survey demonstrated a number of significant differences in the individual weights, the condition of the fish, as well as in the mensural and meristic characters. Out of a total of 28 analysed linear parameters, such differences were recorded in 15 characters in summer and in as many as 19—in autumn. Also 3 out of 11 meristic parameters showed differences. Vendace of Pełcz Lake, among other things, had larger (related to fork length, *FL*) linear dimensions of individual body parts and they had smaller maximal body depth. The reasons behind the above-mentioned differences may be different environmental conditions of both lakes.

INTRODUCTION

Considering its economical importance the vendace has been considered one of the most important items of the ichthyofauna of Polish lakes. This is mainly because of favourable biological features of this species, namely: short (2-3 years) period of attaining market size, relatively fast growth rate, schooling behaviour facilitating catches, and most of all—the high meat value, making it a desirable consumer item. The above features as well as the existing problems with maintaining on high level traditional eel fisheries, contributed to the fact that "vendace management model" of lakes has been constantly developing since 1990s in water bodies environmentally suitable for this easily adaptable species (Leopold et al. 1998).

Tough economic laws affecting fisheries practice have prompted an increasing number of efforts to stock lakes with vendace hatch. Not all of them were successful. Unfortunately, the fry is not always released to the lake of its origin. Sometimes other water bodies are stocked, even those having their endemic populations of this fish. Such practices lead to crossbreeding and merging of different populations of this species, which in turn, translates into the loss of unique morphometric features of vendace characteristic for a given body of water. Out of 1575 lakes located in the Zachodniopomorskie Voivodeship (Filipiak and Raczynski 2001), 44 have been assigned to the "vendace type". In only 23, however, vendace has been exploited commercially (Czerniejewski and Filipiak 2001). Very few papers were published describing biological and morphometric parameters of vendace inhabiting lakes in above-mentioned area. Walczak (1953) and Gałowska (1973) studied the above-mentioned parameters in vendace of lakes Kaleńsko, Krzemień, and Bucierz. The latter author studied also vendace from Lake Miedwie. They observed substantial differences, among other things, in the overall shape of the body between populations of this fish from different lakes. They attributed those differences to different environmental conditions and distinct morphometric differences of those bodies of water. Earlier, Thienemann (1933) and Nikanorov (1964) published similar remarks on the influence of the lake size on the biometric parameters of vendace. The lack of contemporary literature data on biological and biometric characteristics of different populations of vendace inhabiting lakes of the Zachodniopomorskie Voivodeship and also long-term poor management of this fish species prompted the present authors to commence studies intended to fill this gap of knowledge and to help improve the existing situation. The aim of the present paper is to compare the most important biological and morphometric features of vendace representing two—trophically-different and important for fisheries practice—lakes: Drawsko and Pełcz.

MATERIAL AND METHODS

The material for the present study were vendace originating from lakes Pełcz and Drawsko. The fish were sampled in summer (group I or "summer group") and autumn (group II or "autumn group"). The fish were acquired during commercial catches, using anchored gillnets, 24-mm mesh size. Pełcz Lake yielded 120 vendace caught on 28 July 2000 and 104 specimens caught on 2 October 2000. The study on Drawsko Lake vendace was carried out on 106 fish caught on 2 August 2000 and on 110 specimens randomly selected from the catch conducted on 5 October 2000. All vendace were iced and promptly transported to the Department of the Fisheries Management of Inland Waters, Agricultural University of Szczecin. After the arrival they were divided into groups of 10, placed in special two-wall plastic bags (to prevent sublimation of water from the tissues), and frozen at -28°C . The fish were stored at the same temperature for up to three weeks and the bags

were slowly defrosted, one at a time. Defrosted fish were weighed to the nearest 0.1 g on an electronic balance of the "Axis" type and subsequently subjected to a detailed biometric analysis. Also their sex, condition coefficient (Fulton coefficient), and age were determined, the latter based on scale readings. Mensural characters were measured based on the method described by Brylińska (1986) and modified by the present authors (Fig. 1).

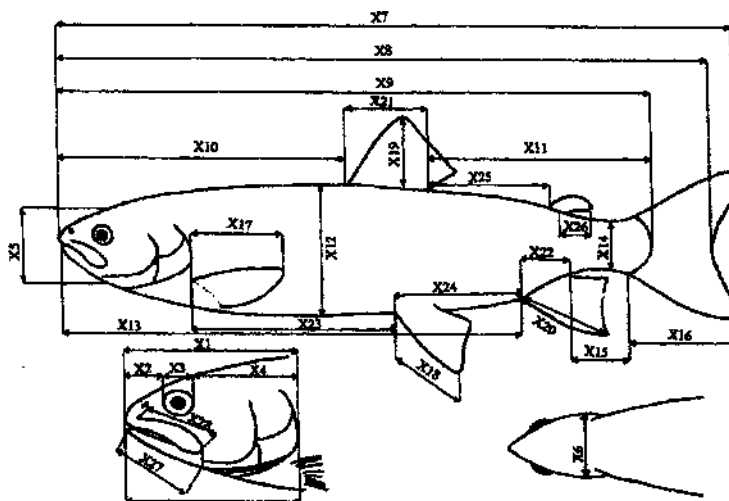

Fig. 1. Diagram of linear measurements of vendace, *Coregonus albula* L. (Brylińska 1986, modified by the present authors)

The modifications consisted in performing additional measurements: the distance between the dorsal fin and the adipose (x25), adipose length (x26), lower jaw length (x27), and the upper jaw length (x28). All 28 linear measurements were taken with an electronic slide calliper "Helios" to the nearest 0.01 mm. A custom-made software Com2exel, developed in our Division was used for simultaneous data transfer from the calliper to a computer. The data were statistically analysed with the aid of MS Excel and Statistica software. Using the method of Smitt (1886), the linear dimensions of the body were expressed in relative values (%), related to the fork length of the fish (x8). The meristic analyses included the lateral line scale count (*l./l.*), number of gill rakers on the first gill arch (*Sp.br.* 1), number of branchiostegal rays (*r. branch.*), number of spines in: dorsal fin (*D*), anal fin (*Ä*), pelvic fin (*V*), and pectoral fin (*P*), and soft rays (*r.d.*) in the above-mentioned fins. The counting procedure was aided by a probe and a dissecting microscope (magnification: 2.5x). All mensural and meristic data were processed statistically yielding the following parameters: range, arithmetic mean, and coefficient of variation (CV). We assumed after Ruszczyk (1981) that coefficient of variation was statistically significant when it attained

value of 10%. The features, for which, $CV > 10\%$, were considered highly plastic. The Mann-Whitney U test was also used, to determine significance of differences of the features studied between fish from both lakes. A discriminant analysis (Sokal and Rohlf 1998) was used to verify levels of differences and correctness of the results.

Morphometric and hydrochemical characteristics of lakes Drawsko and Pełcz

The surface area of Lake Drawsko covers 1871.5 hectares, which makes it the largest body of water within the Drawskie Lake District and one of the largest within the Pomeraanian Lake District. Because it has been formed at a crossing of a number of glacial valleys it is strongly dendritic. The development factor of the coastal line (WL) is 4.97, while elongation factor (a) is 3.2. The slopes of the lake bed are steep and there are numerous deep spots, the deepest of which (79.7 m) is located in the south-eastern part of the lake. Due to its morphometric features and also because of the Drawa River flowing through, Drawsko Lake is among the water bodies that are, in high extent, resistant to eutrophication. The direct drainage basin is covered predominately by forests. According to Bernatowicz et al. (1975) the oxygen content in this body of water measured between the surface and the bottom was not lower than $2 \text{ mg} \cdot \text{dm}^{-3}$, which constitutes a limit of the oxygen demand of vendace. The most recent study of the Drawsko Lake waters, carried out during summer stagnation (Cyzdik et al. 2000) confirmed high quality of its waters, evidenced, among other things by relatively high ($4.3\text{--}6.0 \text{ mg} \cdot \text{dm}^{-3}$) oxygen content in the benthic layers. Favourable oxygen contents and suitable food base observed for many years now, have enabled a rational fisheries management, with strong emphasis on catches of coregonids. Within 1995-2000 the annual average catch of vendace in this lake fluctuated between $1.76 \text{ kg} \cdot \text{ha}^{-1}$ (2000) and $14.62 \text{ kg} \cdot \text{ha}^{-1}$ (1997) with the average value of $5.93 \text{ kg} \cdot \text{ha}^{-1}$ (data from the lake book)

Pełcz Lake compared to Drawsko Lake is smaller (279.5 ha) and it is located in the nearby Choszczeńskie Lake District. It shows much lower WL factor (3.34) and at the same time, much higher elongation factor ($a = 11.5$). Its bed, well carved in moraine formations also features numerous deep spots (maximal depth 31 m). The lake represents a non-flow-through type and its direct drainage basin is covered predominantly by fields which causes periodical (summer) worsening of the water quality. A hydrochemical survey carried out in 1994 (Cyzdik et al. 2000) revealed a complete absence of oxygen as high as in the lower part of metalimnion and in the entire hypolimnion, and the presence of hydrogen sulphide above the bottom of the lake. Unfavourable environmental conditions were the main reason behind the decline of the vendace population in Pełcz Lake in the 1990s. As recently as within 1980-1990 the mean catch efficiency was $18.5 \text{ kg} \cdot \text{ha}^{-1}$, whereas in the last decade it dropped down to $6.7 \text{ kg} \cdot \text{ha}^{-1}$ (according to the lake book). It must be emphasised that a

drastic collapse of commercial catches was observed throughout the year 2000 as a consequence of a complete oxygen deficiency in the water layers deeper than 7 m.

RESULTS

The comparison of biological parameters of group 1 vendace (caught in summer) revealed that the Drawsko Lake fish compared to those of Pełcz Lake were longer (*TL* by 17.4 percentage points; *FL* by 18.4 percentage points) and their individual weight was by 72.6 percentage points higher (Table 1). Consequently also their condition expressed by the Fulton coefficient was by 14.1 percentage points higher. The principal factor causing above-mentioned differences was the different age structure of fish analysed. The dominant group in both lakes were vendace aged 2+ In Drawsko Lake they constituted 69.8% and their average individual weight was 87.6 g, while in Pełcz—50.8% and 57.6 g, respectively). In the material, however, coming from the former body of water the share of 4-year-old specimens—attaining average individual weight of 127.4 g—was as many as 30.2%, whereas in Pełcz Lake (average weight of 82.7 g) it was below 3.3%. Moreover, the dominant (40.8%) item in the latter lake were small vendace (46.2 g) aged 1+. The percentage of females in Pełcz Lake was 77.5%, whereas in Lake Drawsko—only 43.3%.

The data presented in Table 2 indicate also a substantial disproportion in biological characters between vendace from lakes Pełcz and Drawsko caught in the autumn. In the former lake the range of individual weight of fish was 21.5–85.3 g, while in Drawsko Lake the analysed fish were much heavier (69.2–221.6 g). It is also interesting that the average individual weight of fish from Pełcz Lake were as many two times higher compared to "autumn specimens" from Drawsko Lake and the difference between total lengths was 22.2 percentage points, while between fork lengths—23.2 percentage points. In all above-mentioned parameters—similarly as in vendace caught in summer—distinct differences were noted for each sex of this fish from both lakes. For example in "autumn" males from Pełcz Lake, mean individual weight was two times higher than the weight of males from the other lake, whereas the same parameter between females differed three times. The age structure of fish from both bodies of water, in large extent, explains the differences observed in the studied biological parameters. Even if the dominant age group in lakes Pełcz and Drawsko were three-year-old fish, weighing on average 47.9 g and 87.6 g, respectively, the former lake featured also 22.1% of fish aged 1+ (average weight 32.4 g) and 2.9% of those aged 3+ (71.0 g), while in Drawsko Lake as many as 27.3% constituted four-year-old specimens (127.4 g) and five-year-old (190.1 g). At the same time a disproportion was observed in the sexual composition of this fish. Similarly as in "summer" group, also the "autumn" vendace from Drawsko Lake featured 3 times fewer females (28.19%) than in Pełcz Lake (84.57%).

Table 1

Basic biological data of vendace acquired in summer for morphometric study

Capture site	Sex	Sample size	Value	<i>TL</i> [mm]	<i>FL</i> [mm].	Total weight [g]	Fulton coefficient	Number of fish in each age group:		
								1+	2+	3+
Drawsko Lake	Total	106	Mean	230.2	208.8	95.8	1.05	—	74	30
			Minimum	207.0	186.0	69.1	0.88			
			Maximum	259.0	234.0	147.8	1.22			
	Females	47	Mean	233.3	211.5	100.1	1.05	—	32	15
			Minimum	215.0	196.0	80.1	0.90			
			Maximum	259.0	234.0	147.8	1.22			
	Males	59	Mean	227.7	206.8	92.5	1.04	—	44	15
			Minimum	207.0	186.0	69.1	0.88			
			Maximum	259.0	233.0	146.7	1.16			
Pełcz Lake	Total	120	Mean	196.1	176.3	55.5	0.92	49	61	7
			Minimum	154.1	136.0	30.5	0.68			
			Maximum	258.0	225.0	110.6	1.10			
	Females	93	Mean	197.6	177.9	57.3	1.00	32	52	6
			Minimum	154.2	136.7	31.2	0.76			
			Maximum	258.0	238.0	110.6	1.23			
	Males	27	Mean	190.6	170.8	49.1	0.98	17	9	1
			Minimum	160.0	142.8	30.5	0.82			
			Maximum	218.4	196.6	72.3	1.28			

Table 2

Basic biological data of vendace acquired in autumn for morphometric study

Capture site	Sex	Sample size	Value	TL [mm]	FL [mm].	Total weight [g]	Fulton coefficient	Number of fish in each age group:			
								1+	2+	3+	4+
Drawsko Lake	Total	106	Mean	227.83	206.71	101.9	1.13	—	80	24	6
			Minimum	197.20	181.80	69.2	0.92				
			Maximum	284.90	258.60	221.6	1.45				
	Females	47	Mean	237.89	215.65	127.6	1.22	—	13	13	5
			Minimum	202.20	181.80	70.7	1.01				
			Maximum	284.90	258.60	221.6	1.45				
	Males	59	Mean	223.89	203.20	91.8	1.09	—	66	12	1
			Minimum	197.20	185.30	69.2	0.92				
			Maximum	276.20	250.10	156.0	1.24				
Pełcz Lake	Total	120	Mean	177.16	158.83	45.2	1.11	23	78	3	—
			Minimum	149.02	133.36	21.5	0.69				
			Maximum	213.89	196.93	85.3	1.45				
	Females	93	Mean	176.20	157.95	45.3	1.14	3	11	1	—
			Minimum	149.02	133.36	29.1	0.59				
			Maximum	213.89	194.72	85.3	1.43				
	Males	27	Mean	182.87	164.04	44.4	0.98	3	11	1	—
			Minimum	151.19	136.07	21.5	0.78				
			Maximum	213.68	196.93	66.6	1.16				

The relation between the total length and the individual weight of both groups of vendace, shown on Fig. 2, indicate substantial differences between material acquired from Drawsko Lake and that caught in Pełcz Lake. Both in summer and in autumn, vendace from the former lake showed distinctly better condition, increasing along the increase of the total length. It must be emphasised that the higher condition was observed in vendace collected in autumn, which was associated with the maturation of their gonads at that time. Vendace of Pełcz Lake did not show this regularity and the power functions describing relations between the length and the weight did not differ much between samples of summer and autumn. It is interesting that in vendace of both lakes caught in summer the determination coefficient was distinctly higher than in "autumn" group. It means that the latter group was characterised by a wider ranger of individual weight of fish having the same total lengths.

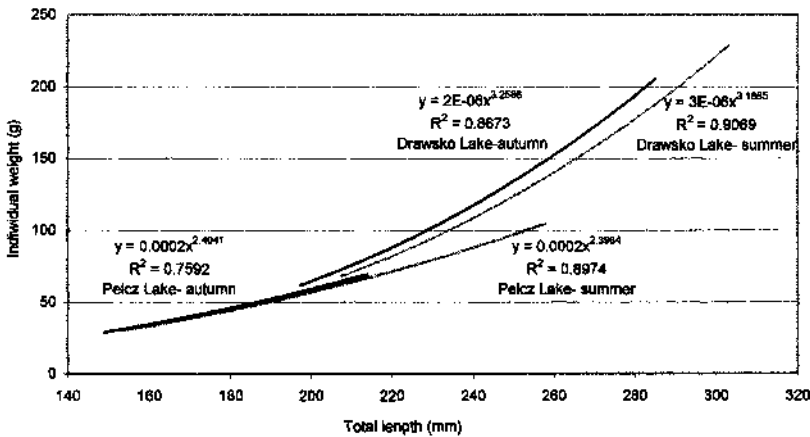

Fig. 2. Relation between the total length and individual weight of vendace from lakes Drawsko and Pełcz

Mean values of mensural and meristic characters with their coefficient of variation (CV) for group 1 (summer) of vendace is shown in Table 3, while for group 2 (autumn)—in Table 4. Coefficients of variation for group 1 fish from both lakes were high ($CV > 10$) for the adipose fin length (x26) and the length of caudal peduncle (x15). The CV values of the former parameter were 10.41% in Drawsko Lake and 14.49% in Pełcz Lake, while for the latter parameter they were 10.20% and 12.73%, respectively. In group 2, the CV values for x26 were 15.41% in Drawsko Lake and 11.84% in Pełcz Lake, while for x15—10.61% and 9.20%, respectively. The above-mentioned features should be considered highly plastic and taking this into account they were rejected from further statistical analysis.

Table 3

Ranges, mean values, and coefficients of variation of mesural and meristic characters of vendace caught from lakes Drawsko (106 specimens) and Pełcz (120)

Character code	Drawsko Lake			Pełcz Lake			Discriminant analysis (λ)
	Range	Mean	CV	Range	Mean	CV	
Mesural characters (in % of fork length)							
x1*	17.33-20.84	18.87	4.97	19.60-24.02	21.70	4.47	0.142652
x2*	3.88-5.68	4.38	7.27	4.52-6.37	5.48	7.11	0.096844
x3*	4.19-5.70	5.04	6.60	4.82-6.76	5.83	7.12	0.108764
x4*	7.87-10.73	9.42	5.32	9.06-12.11	10.59	5.80	0.082348
x5*	9.22-12.00	10.73	7.51	11.28-14.93	13.46	6.26	0.048364
x6	7.51-9.34	8.41	5.24	7.40-10.08	8.56	5.76	—
x7	105.58-115.76	110.25	1.18	101.07-116.09	112.02	1.95	—
x9*	90.95-97.01	95.14	1.04	89.43-97.67	93.99	2.15	0.091757
x10*	39.87-47.68	42.66	3.25	38.43-47.56	44.21	3.40	0.04787
x11	37.80-45.94	40.30	4.48	24.86-44.85	39.94	8.19	—
x12*	17.90-23.06	20.52	5.76	12.75-22.73	18.42	8.15	0.129701
x13	63.57-74.65	68.29	3.67	47.71-73.06	68.65	7.69	—
x14	5.87-9.39	6.71	7.28	5.70-10.39	6.72	8.92	—
x15a	9.11-13.18	10.57	10.20	6.13-11.80	8.72	12.73	—
x16*	18.17-25.86	22.04	9.43	19.41-31.16	23.89	8.61	0.032911
x17	14.10-16.75	15.33	4.28	12.21-17.95	15.49	7.02	—
x18*	12.65-16.98	14.44	5.02	12.27-18.40	15.03	6.93	0.0326482
x19	12.00-16.98	14.98	9.73	12.15-18.81	14.40	8.57	—
x20*	9.33-12.98	11.65	8.68	8.15-11.91	10.24	9.79	0.045513
x21	7.69-11.00	9.53	6.61	6.31-12.07	9.60	9.01	—
x22	10.00-14.13	12.11	8.03	9.36-12.37	11.58	8.57	—
x23*	24.46-31.31	28.10	5.11	23.58-29.79	27.22	4.56	0.045234
x24*	18.78-24.74	22.20	5.71	20.31-27.62	23.02	5.68	0.046709
x25	20.29-27.89	24.98	5.12	21.55-29.31	24.41	5.36	—
x26a	4.35-5.32	4.83	10.41	2.99-6.43	4.24	14.49	—
x27*	7.89-8.96	8.25	5.23	8.38-11.64	9.91	7.10	0.172133
x28*	5.23-6.01	5.55	5.67	5.87-7.49	6.62	6.40	0.066604
Meristic characters							
<i>D</i>	3-3	3	0	2-3	2.99	0	—
<i>rd.D</i> *	8-10	9.67	5.46	7-10	8.58	7.89	0.045369
<i>A</i>	3-3	3	0	3-3	3	0	—
<i>rd.A</i> *	11-15	12.03	7.33	9-14	11.10	7.37	0.044621
<i>V</i>	2-2	2	0	2-2	2	0	—
<i>rd.V</i>	9-11	10.07	6.94	9-11	9.85	5.38	—
<i>P</i>	1-1	1	0	1-2	1.01	0	—
<i>rd.P</i>	10-14	13.25	7.63	12-15	13.55	5.64	—
<i>r.br.</i>	7-8	7.06	3.89	7-8	7.13	4.82	—
<i>sp.br.</i> 1	37-41	39.13	3.09	36-43	38.93	4.93	—
<i>l.l.</i> *	72-87	82.64	3.58	73-85	77.97	4.05	0.054044

* statistically significant differences ($p < 0.05$), characters rejected from data subjected to further statistical analysis.

Of the remaining 25 mensural features of vendace, expressed in percents of total length, the lowest variability ($CV < 3\%$) in both groups (1 and 2) and from both lakes Drawsko and Pełcz, was stated in: the standard length (x9) and the total length (x7). In vendace collected in autumn the lowest CV was observed also in the preanal distance (x13). It is important that the CV differences, ranging from 2.4 to 4.1% between the fish of summer catch from lakes Drawsko and Pełcz, were found for seven mensural features (x11, x12, x13, x15, x17, x21, and x26) and for two meristic characters (*rd.D* and *sp.br1*). The above-mentioned higher CV differences in "summer" vendace of Pełcz Lake suggested higher morphometric variability of those fish compared to vendace collected at the same season from Drawsko Lake. CV differences, ranging from 2.5 to 3.6% in "autumn" vendace between lakes Pełcz and Drawsko were observed in two mensural features only (x4 and x26) and in a single meristic character (*rd.P*).

Table 3 shows also comparative results of biometric characters of vendace acquired in summer from lakes Drawsko and Pełcz in a form of a non-parametric Mann-Whitney U test. Out of 25 mensural features (presented in relative values) as many as 15 exhibited statistically significant differences, whereas in the case of 11 meristic characters such differences were visible only in the lateral line scale counts (*l.l.*), the number of soft rays in the dorsal fin (*r.d.D*), and in the anal fin (*r.d.A*). To determine the level of differences of respective morphometric features of "summer" vendace of both lakes a discriminative analysis was used. It can be concluded from the calculated lambda indices that the most extensive differences between the fish from lakes Pełcz and Drawsko were visible in the following features: x27, x1, x12, x3, x2, x9, and x4. It must be emphasised that as many as 5 of the above-mentioned characters describe dimensions of the vendace head. Slightly smaller differences ($\lambda < 0.08$) were noted in 8 remaining linear measurements and in 3 meristic characters (Table 3). Correctness of these results measured with a classification matrix was obtained at the level of 92.6%. It amounted to 96.8% for vendace of Drawsko Lake and to 88.4% in the case of Pełcz Lake fish.

Substantial differences were also stated between vendace of acquired in autumn from lakes Pełcz and Drawsko. Results of U test of Mann-Whitney shown in Table 4 demonstrated differences between studied fish from both lakes in as many as 19 linear parameters and 3 meristic characters. The highest levels of differences ($\lambda > 0.08$) were observed (in decreasing order) in x27, x1, *rd.D*, x3, x12, and x6. Except for the number of soft rays in the dorsal fin (*rd.D*) and maximal body length (x12) the remaining parameters describe shape and size of the head of the fish studied. Compared to "autumn" vendace of Drawsko Lake the fish from Pełcz Lake—similarly as fish collected in summer—had higher (statistically significant) values of those linear parameters and lower values of maximal depth of the body (x12).

Table 4

Ranges, mean values, and coefficients of variation of mensural and meristic characters of vendace caught in autumn from lakes Drawsko (110 specimens) and Pełcz (104)

Character code	Drawsko Lake			Pełcz Lake			Discriminant analysis (λ)
	Range	Mean	CV	Range	Mean	CV	
Mensural characters (in % of fork length)							
x1*	17.99-21.57	19.94	3.27	17.81-23.53	21.33	4.79	0.091871
x2*	3.84-5.91	4.96	7.96	4.42-6.13	5.56	6.97	0.07449
x3*	4.17-5.99	5.10	7.54	5.16-6.94	6.16	6.98	0.86241
x4*	8.06-11.09	9.86	4.72	7.06-11.92	10.32	7.28	0.0422799
x5*	9.57-13.64	11.97	6.97	8.61-12.65	11.21	6.04	0.049273
x6	7.05-10.38	8.37	8.25	7.89-11.69	9.93	7.16	0.81021
x7	101.01-115.03	110.24	2.35	106.21-116.99	111.08	2.28	—
x9*	89.97-95.96	93.46	2.52	89.54-96.48	93.03	142	—
x10*	38.60-46.76	43.29	3.48	39.44-49.69	44.45	3.91	0.04212
x11	36.62-45.89	41.76	4.00	29.71-41.62	39.11	5.70	0.041374
x12*	17.21-27.02	21.81	8.36	15.93-24.21	19.65	8.75	0.82163
x13	63.78-73.74	68.59	2.40	65.86-76.02	70.54	2.77	0.03262
x14	5.48-7.72	6.77	6.65	5.44-7.63	6.68	6.58	—
x15a	6.84-12.66	9.44	10.61	6.10-10.71	8.79	9.20	—
x16*	15.25-25.92	22.41	8.33	19.26-26.97	22.99	7.14	0.04514
x17	13.62-17.42	15.48	5.03	12.14-17.27	15.21	6.92	—
x18*	12.91-17.94	15.19	6.11	12.61-16.71	14.80	5.81	0.02989
x19	10.97-19.63	14.89	8.17	11.74-17.21	14.15	7.15	0.041701
x20*	9.92-15.71	12.02	8.01	8.44-12.91	11.09	7.85	0.046845
x21	8.57-11.88	9.92	6.69	7.62-11.17	9.19	7.62	0.056646
x22	10.32-15.74	12.41	8.18	10.78-15.91	12.81	8.48	—
x23*	24.89-35.88	28.91	5.94	23.12-31.61	27.98	6.40	0.050884
x24*	18.53-26.30	23.21	6.93	19.82-27.96	24.11	6.33	0.04602
x25	22.31-28.53	25.43	5.49	20.00-26.48	23.54	5.66	0.043516
x26a	2.72-5.78	4.24	15.41	2.42-4.55	3.85	11.84	—
x27*	7.02-9.68	8.38	6.22	7.62-10.69	9.70	5.83	0.139339
x28*	5.06-8.87	6.04	7.87	5.11-7.81	6.48	8.17	0.047765
Meristic characters							
<i>D</i>	3-3	3	0	3-3	3	0	—
<i>rd.D</i> *	7-10	9.72	5.59	8-9	8.72	5.16	0.090123
<i>A</i>	3-3	3	0	3-3	3	0	—
<i>rd.A</i> *	10-15	11.75	8.16	10-13	11.33	6.22	0.042799
<i>V</i>	2-2	2	0	2-2	2	0	—
<i>rd.V</i>	9-11	10.15	5.36	10-11	10.15	3.57	—
<i>P</i>	1-1	1	0	1-1	1	0	—
<i>rd.P</i>	10-14	13.47	7.01	13-15	13.45	4.29	—
<i>r.br.</i>	7-7	7	0	7-7	7	0	—
<i>sp.br.</i> 1	35-41	40.33	4.68	38-43	40.2	3.42	—
<i>l.l.</i> *	72-86	83.13	4.12	75-88	81.74	3.45	0.03216

* statistically significant differences ($p < 0.05$),

a, characters rejected from data subjected to further statistical analysis.

DISCUSSION

In Lakes of Polish Western Pomerania vendace has been caught using anchored gill nets of the mesh size of 24 mm, targeting 3-year-old specimen (Bernatowicz et al. 1975). Despite the employment of relatively selective fishing gear the fish acquired from lakes Pełcz and Drawsko exhibited relatively high variability of basic biological parameters (weight and length). This enabled us to conduct comparative studies on the growth rate of length and weight with vendace from other lakes of Western Pomerania also exploited with the aid of anchored gill nets of the same parameters.

Based on the age studies of vendace collected from 205 lakes of Poland Marciak (1970) demonstrated that, similarly as in the age structure in lakes Pełcz and Drawsko, the dominant group in all year seasons were 3-year-old fish. It is possible that small differences in the age of vendace between both lakes resulted from fisheries management of Pełcz Lake, which failed to consider the worsening environmental conditions there. The latter fact was farther evidenced by a rapid (over 20 times) decline in catches of vendace within 1995-1999, despite the constant fishing effort. The above-mentioned situation contributed to "overfishing" and small representation of 3+ and older specimens in the samples collected in summer and autumn of 2000 from Pełcz Lake.

The head has been considered one of the most morphometrically variable parts of fish body (Gašowska 1973; Radziej 1973). Results of statistical tests and discriminative analysis of the present study confirmed that among 27 mensural and 11 meristic features studied, in both summer and autumn sample, the highest differences between vendace were stated particularly in parameters describing the shape of the head. It is evident from the literature data (Kozikowska 1961; Gašowska 1973) that the lateral length of head fits within 18.4-22.6% of the fork length. Thienemann 1933, using data from Mecklenburg (Germany) and Pomeranian and Masurian (presently in Poland) lakes determined differences in much higher range (14.3-24.8%). Despite statistically significant differences in the lateral length of head (x_1) in vendace from lakes Drawsko and Pełcz the mean values of this parameters in "summer" group of these fish amounted to 18.87 and 21.70%, respectively, while in the "autumn" fish—19.94 and 21.33%, respectively, which makes them consistent with the ranges most often quoted in the literature (Kozikowska 1961; Gašowska 1973). The data collected by Sandlund (1997) suggest that the lateral head length usually correlates with the remaining dimensions of this part of fish body. Therefore the vendace acquired in summer and autumn from Pełcz Lake, in contrast to those from Drawsko Lake, showed higher dimensions of linear parameters of the head, which was statistically significant. The highest level of differences between morphometric features in both "summer" and "autumn" vendace was observed in the length of the lower jaw (x_{27}). The fish from Drawsko Lake attained distinctly lower mean value of this parameter (summer 8.25% and

autumn 8.38%) compared to Pełcz Lake (9.91% and 9.70%, respectively) and to data of Radziej (1973) for Wierzbiczy Lake (9.0%) and Narie Lake (10.0%).

An important mensural feature is the diameter of the eye. Variability of this parameter in vendace of lakes Breite Lucin and Stechlin enabled differentiation of two forms of this fish: "nominat form" and "deepwater form" (Thienemann 1933; Anwand et al. 1997). This parameter in vendace from deeper bodies of water is distinctly higher. For example, Radziej (1973) determined that the eye diameter in vendace of Narie Lake (max depth 43.8 m) was 5.7%, whereas in Wierzbiczy Lake (max. depth 21.6 m) it was 4.9%. Kozikowska (1961) suggested that the values of the eye diameter might be influenced not only by the depth but also by the transparency of water. On the other hand, in the case of vendace collected in both seasons from lake Drawsko and Pełcz the difference in this linear parameter as well as in the remaining mensural parameters of the head are difficult to justify consistently. It is possible that the elevated values of the above-mentioned linear parameters of vendace from Pełcz Lake were caused by a limited access to food resulting from abnormal overcrowding of all fishes in the narrow epilimnion zone, which was the only zone where oxygen was present.

The condition of fish is an indirect reflection of hydrochemical and hydrobiological conditions observed in a given body of water. Its exponent is the maximum depth of fish body (Kozikowska 1961). Most often the values of this feature range from 19.11% (Bucierz Lake) to 23.29% (Płęsno Lake) (Kozikowska 1961; Gašowska 1973). Even if the mean values of the maximum height of the body of vendace from lakes Drawsko and Pełcz fit into the range determined for Polish lakes, the statistical analyses performed, have demonstrated significant differences in this feature. Similar dates of collecting the fish from both lakes, rule out possible effect of the developmental advancement of gonads on the above parameter. Most probably those differences were caused by unstable and unfavourable hydrochemical conditions occurring in summer in Pełcz Lake (limited water layer containing suitable oxygen concentrations and unsuitable—too high water temperature) and hydrobiological ones (limited access to food resulting from the earlier mentioned excessive concentration of fishes representing all species in a narrow—reaching depth of 7 m—oxygenated zone). The above factors could have been the reasons behind distortion of the body shape of vendace acquired in summer and in autumn and "creation" of hunger forms of these fish in Pełcz Lake which was reflected in the values of the discussed linear parameters of the head and the maximum body height.

Statistically significant variability of vendace of both lakes in their meristic characters was observed in the number of scales in the lateral line (*ll*). The above feature shows an extensive variability. For example, the range of the number of scales in the lateral line was in lakes: of Sweden 65-90 (Smitt 1886), of Poland, 72-91 (Gašowska 1962, 1973),

of Byelorussia, 70-90 (Galcova 1954), and Russia, 72-90 (Pokrovskij 1967). The remaining meristic features (*rd.D.* and *rdA.*) which enable differentiation between vendace from both lakes studied, are consistent with the data most often cited in the literature (Table 5). It must be emphasised that the low number of gill rakers recorded in vendace of lakes Drawsko and Pełcz (35-41 and 38-43, respectively). Walczak (1953) and Gaşowska (1973) attributed the number of gill rakers to the specific character of the environment in different bodies of water. The highest values of this feature vendace reaches in lakes similar to oligotrophic type, while the lowest numbers—in eutrophic ones.

Table 5

A checklist of meristic characters of vendace according to different authors
(including present data from lakes Pełcz and Drawsko)

Area surveyed	Author	Number of soft rays in fins:		Number of scales	Number of gill rakers
		<i>D</i>	<i>A</i>		
Sweden	Smitt(1886)	8-10	10-13	65-90	36-49
Charzykowo Lake	Walczak (1953)	8-11	9-14	—	39-48
Bucerz Lake		7-10	9-12		35-44
Krzemień Lake		8-10	10-14		42-51
Kaleńskie Lake		8-11	10-14		36-51
Naroć Lake	Galcova (1954)	8-11	10-14	70-90	36-46
Poland	Gaşowska (1962)	8-9	10-13	72-84	35-52
Onęga Lake	Pokrovskij (1967)	7-10	10-14	72-90	39-49
Łańskie Lake	Gaşowska (1973)	8-10	10-13	75-91	41-9
Wigry Lake		7-9	10-12	75-90	40-49
Mamry Lake		8-9	10-12	77-40	41-45
Miedwie Lake		8-9	10-12	73-88	37-47
Bucerz Lake		7-9	10-12	78-91	37-43
Pełcz Lake	Present data	7-10	9-14	73-88	36-43
Drawsko Lake		7-10	10-15	72-87	35-41

Different environmental conditions of both lakes had a decisive effect on formation of mensural and meristic features of vendace. It is possible that the linear parameters of the fish studied in substantial way were affected by the individual hydrochemical factors (water temperature and oxygen level) affecting directly the quality, quantity, and the availability of food and probably also some morphometric elements of those bodies of water (water surface area and depth) mentioned by Nikanorov (1964), Radziej (1972), or Thienemann (1933). Therefore the knowledge on the biology of those fish should be also supplemented by hydrochemical analyses of vendace lakes, which may be of crucial importance of a rational fisheries management.

CONCLUSIONS

1. Meristic features of both groups of vendace of Pełcz Lake can be expressed using the following formula: *D* Π-III 7-10, *A* III 9-14, *VII* 9-11, *PI*-II 12-15, *r.br.* 7-8, *sp.br.* 36-43, *l.l.* 73-88, whereas for Drawsko Lake—*D* Π 7-10, *A* III 10-15, *VII* 9-11, *PI* 10-14, *r.br.* 7-8, *sp.br.* 35-41, *././.* 72-87.
2. Vendace of Pełcz Lake caught in summer as well as in autumn were characterised by only three meristic features assuming higher values (statistically significant difference) than the respective features in the fish of Drawsko Lake: number of scales on the lateral line (*l.l.*), number of soft rays in dorsal fin (*rd.D.*) and anal fin (*rd.A.*)
3. Statistical analysis revealed significant differences between vendace of both lakes in 15 mensural features in summer and in as many as 19 in autumn. The highest level of differences was visible in linear dimensions of the head and in maximal height of the body.
4. Out of the 27 linear parameters of vendace caught in summer and in autumn in both lakes a low variability ($CV < 3\%$) was stated in the total length (*TL*) and in standard length (*SL*), whereas the highest variability ($CV > 10\%$) was stated in the length of adipose fin and in the length of caudal peduncle.
5. Because of unfavourable oxygen conditions, vendace of Pełcz Lake characterised themselves substantially lower individual weight values and lower condition compared to vendace acquired Drawsko Lake—hitherto resistant to eutrophication.

REFERENCES

- Aowand K., G. Staaks, M. Valentin**, 1997: Zwei unterschiedliche Formen von *Coregonus albula* (Teleostei; Coregonidae) im nordbrandenburgischen Stechlinsee (Deutschland), *Z. Fisch.*, Solingen, 4, 1-2: 3-14.
- Bernatowicz S., W. Dembiński, J. Radziej**, 1975: Sielawa [Vendace]. PWRiL, Warszawa. (In Polish).
- Brylińska M., (ed.)**, 1986: Ryby słodkowodne Polski [The freshwater fishes of Poland]. PWN, Warszawa. (In Polish).
- Cydzik D., D. Kudelska, H. Soszka**, 2000: Atlas stanu jezior Polski badanych w latach 1994-1998 [Atlas of the state of Polish lakes surveyed within 1994-1998]. Inspekcja Ochrony Środowiska, Biblioteka Monitoringu Środowiska, Warszawa. (In Polish).
- Czerniejewski P., J. Filipiak**, 2001: Występowanie sielawy (*Coregonus albula* L.) w jeziorach Pomorza Zachodniego, [Presence of vendace, *Coregonus albula* L. in lakes of Polish Western Pomerania], *Kom. Ryb.*, 5: 3-7. (In Polish).
- Filipiak J., M. Raczyński**, 2001: Jeziora Zachodniopomorskie. [Lakes of Polish Western Pomerania]. Wyd. AR Szczecin. (In Polish).

- Galcova M.U.**, 1954: Rjapuška (*Coregonus albula* L.) ozera Naroć [Vendace, *Coregonus albula* L. of Naroć Lake]. Učenyje Zapiski, Mińsk, 17: 96-108. (In Russian).
- Gąsowska M.**, 1962: Klucze do oznaczania kręgowców Polski. Część I Kragłouste i ryby [Keys for identification of vertebrates of Poland. Part I. Cyclostomes and fishes]. PWN, Warszawa-Kraków. (In Polish).
- Gąsowska M.**, 1973: Porównawcze, biometryczne studia sielawy (*Coregonus albula* Linnaeus 1758) (*Pisces*, Coregoninae) z jezior Polski i niektórych krajów ościennych [Comparative and biometric studies of the *Coregonus albula* (Linnaeus 1758) (*Pisces*, Coregoninae) from the lakes of Poland and some neighbouring countries]. Roczn. Nauk Rol., 95-H-1: 41-54. (In Polish).
- Kozikowska Z.**, 1961, Wpływ środowiska na morfologię i biologię ryb. Sielawa, okoń: elementy wybrane [The effect of environment on morphology and biology of fishes. Vendace, perch: select elements]. Ekol. Pol., ser. A, 9: 541-678. (In Polish).
- Leopold M., M. Bnińska, A. Wołos, M. Mickiewicz**, 1998: Znaczenie, stan i uwarunkowania rozwoju rybactwa jeziorowego w Polsce [Importance, current state, and factors influencing development of lacustrine fisheries in Poland]. Wyd. IRS, Olsztyn. (In Polish).
- Marciak Z.**, 1970: Zagospodarowanie jezior sielawą [Fisheries management of vendace in lakes]. IRS, Olsztyn, 39. (In Polish).
- Nikanorov J.L.**, 1964: Morfologiczne osobennosti lokalnych stad europejskiej rjapuški *Coregonus albula* (L.) v zavisimosti ot uslovii obitanija [Morphological peculiarities of local stock of the European vendace, *Coregonus albula* (L.) depending on environmental conditions]. Vopr. Ihtiol., 4, 3: 411-422. (In Russian).
- Piasecki W.**, 2000: Sprawozdanie z badań hydrochemicznych i hydrobiologicznych wykonanych na jeziorze Pełcz Wielki 28.08.2000 r., Maszynopis. Zakład Hydrobiologii. Akademia Rolnicza w Szczecinie, [Report on hydrochemical and hydrobiological survey of Pełcz Wielki Lake (28 Aug 2000)]. Typescript. Division of Hydrobiology. Agricultural University of Szczecin. (In Polish).
- Pokrovskij V.V.**, 1967: O morfologicznych osobennostjach proischożdenii i geograficzeskomo rasprostranienii belomorskoj rjapuški *Coregonus sardinella maris-albi* Berg [On morphological peculiarities, origin, and geographical dispersal of the White-Sea vendace, *Coregonus sardinella maris-albi* Berg]. Izv. VNIORCh, 62: 100-114. (In Russian).
- Radziej J.**, 1973: Wpływ środowiska na wolnorosnącą sielawę *Coregonus albula* (Linnaeus 1758) wsiedloną z jeziora Narie do jeziora Wierzbiczany [The effect of environment upon slowly growing vendace, *Coregonus albula* (Linnaeus 1758) transferred from Narie Lake to Wierzbiczany Lake]. Roczn. Nauk Rol., 95-H-1: 129-146. (In Polish).
- Ruszczyc Z.**, 1981: Metodyka doświadczeń zootechnicznych [Methodology of experiments in animal husbandry]. PWRiL, Warszawa. (In Polish).
- Sandlund O.T.**, 1997: Differences in the ecology of two vendace populations separated in 1895. Nordic J. Freshw. Res., 67: 52-60.
- Smitt F.A.**, 1886: Kritisk forteckning over de i Riksmuseum befnitliga Salmonider, Handl. Svenska Vet. Akad., 21 (8): 1-290.
- Sokal R.R., F.J. Rohlf**, 1998: Biometry: the principles and practice of statistics in biological research, Third Edition, W. H. Freeman and Company, New York.
- Thienemann A.**, 1933: *Coregonus albula lucinensis*, eine Tiefenform der Kleinen Maräne aus einem norddeutschen See. Zugleich ein Beitrag zur Rassenbildung bei *Coregonus albula* L. Z. Morph. Ökol. Tiere., 27: 654-683. (Cited after Bernatowicz et al. 1975).
- Walczak J.**, 1953: Sielawa (*Coregonus albula* L.) kilku jezior Pomorza Zachodniego [Vendace (*Coregonus albula* L.) of several Western Pommerania Lakes]. Roczn. Nauk Rol., 67-B-1: 21-37. (In Polish).

Przemysław CZERNIEJEWSKI, Jarosław FILIPIAK

CHARAKTERYSTYKA BIOLOGICZNO-MORFOLOGICZNA SIELAWY
(*COREGONUS ALBULA L.*) Z JEZIOR DRAWSKO I PEŁCZ

STRESZCZENIE

Materiał do badań stanowiły sielawy pozyskane wontonami o średnicy oczka 24 mm z jeziora Drawsko (2.08.2000 oraz 5.10.2000) i Pełcz (28.07.2000 oraz 2.10.2002). Każdy osobnik został przebadany pod kątem biologicznym (wiek, płeć, masa jednostkowa) oraz biometrycznym - 28 cech wymierzalnych (przedstawionych tabelarycznie w odniesieniu do *longitudo caudalis*) i 11 policzalnych. Z przeprowadzonych analiz wieku ryb wynika, iż zarówno w jeziorze Pełcz jak i jeziorze Drawsko w grupach ryb pozyskanych latem i jesienią dominowały sielawy trzyletnie. W tym pierwszym zbiorniku ryby z obu okresów połowu charakteryzowały się wyraźnie gorszymi współczynnikami kondycji, oraz mniejszą masą jednostkową i długością (*l.t.* i *l.caud.*)

Wysoką zmienność ($V > 10\%$) zarówno dla grup ryb pochodzących z połowów letnich, jak i jesiennych z obu zbiorników stwierdzono w wysokości płetwy tłuszczowej (x_{26}), oraz w długości trzonu ogonowego (x_{15}). Najniższą wartość współczynnika zmienności stwierdzono u sielaw z obu jezior w długościach: ciała - x_9 i całkowitej - x_7 , a także u ryb "Jesiennych" w długości przedanalnej (x_{13}). Test U Manna-Whitneya wykazał istotne różnice w 15 (okres letni) i aż 19 (okres jesienny) cechach wymierzalnych i 3 policzalnych. Sielawa z jeziora Pełcz charakteryzowała się statystycznie istotnie większymi wartościami wymiarów głowy, jak i mniejszymi pomiarami maksymalnej wysokości ciała. Wydaje się, że ze względu na zbliżony termin pobrania materiału z obu jezior, przyczynę tych różnic należy upatrywać w niekorzystnych warunkach środowiskowych, co pośrednio potwierdzają niższe wartości współczynników kondycji sielaw z jeziora Pełcz.

Received: 22 March 2002

Author's address:

Przemysław Czerniejewski MSc
Department of Fisheries Management of Inland Waters
Agricultural University of Szczecin
Kazimierza Królewicza 4, 71-550 Szczecin, Poland

e-mail: zgl@flsh.ar.szczecin.pl

